

# AATi

## Project Case Study

March 2016

### DOHA METRO – Gold Line

**Client:** Qatar Rail

**Contractor:** ALYSJ - Joint Venture

**Product:** Bespoke version of type SN9/55 nosing

**Material:** Nickel Bronze

AATi supplied the final series of cast metal anti-slip stair nosings for the Goldline Mock-up station to ALYSJ. AATi type SN9/55PG3 in cast Nickel Bronze.

ALYSJ is a joint venture of 5 world class organizations: Aktor of Greece, Larsen & Toubro of India, Yapi Merkezi & STFA of Turkey and Al Jaber Engineering of Qatar.

The east-west Gold (Historic) Line extends from Ras Bu Aboud to Al Aziziya. Eleven stations run along the Gold Line:

- Ras Bu Abboud
- Qatar National Museum
- Souq Waqif
- Msheireb ( Interchange station)
- Bin Mahmoud
- Al Sadd
- Joaan
- Al Sudan
- Al Waab
- Sport City
- Al Aziziyah

To keep up to date with all our latest news and projects, follow us on LinkedIn - <https://www.linkedin.com/company/aati-limited> or keep visiting our website for further updates [www.aati.co.uk](http://www.aati.co.uk).

**HIGH PERFORMANCE ANTISLIP ANTIWEAR CAST METAL STAIR NOSING**



DATA SHEET: SN9/55PG3®	
DATE: Feb 2016	ISSUE: 1
ITEM: Stair Nosing	

**Item:** AATi™ type SN9/55PG3® - Stair nosing with silicon carbide granules cast into the metal matrix of the wearing surface.

**Application:** Whilst specifically designed around the physical requirements of the DDA, this stair nosing is suitable for many different applications and exhibits the same longevity and hard wearing/heavy duty characteristics as our larger profile nosings.

**Materials:** Nickel Bronze.

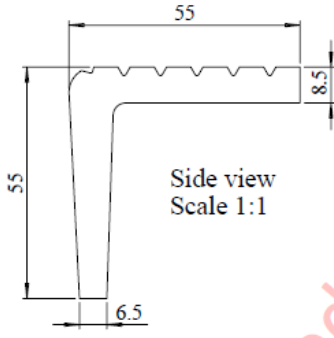
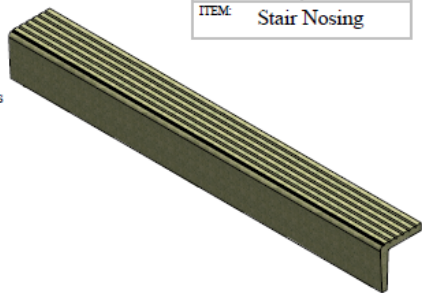

Side view  
Scale 1:1

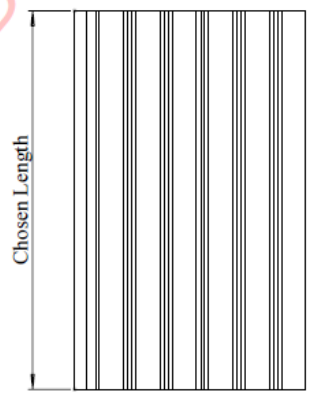

Plan view - scale 1:1

Chosen Length

Special attention should be given to installation & drainage of this product. For further advice please speak to a member of AATi's technical department. Dimensions shown are nominal and subject to AATi manufacturing tolerances.

AATi™ 11 SWINBORNE DRIVE, SPRINGWOOD INDUSTRIAL ESTATE, BRAINTREE, ESSEX, CM7 2YP